

- 01 - K 8 - 102 ou KW - 8-102
- 01 - KT 16 ou KT 305

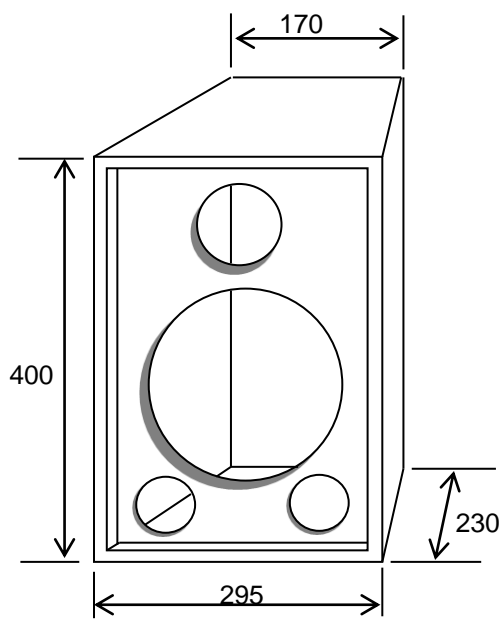

sugestão de divisor de frequências

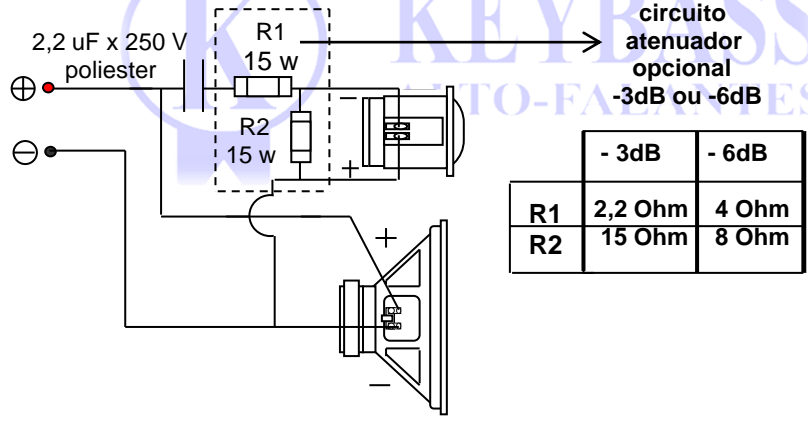

Usar compensado naval ou MDF de 15 mm de espessura.

Caixa acústica de 8" 2 vias ,trapezoidal tipo bass reflex
01 alto-falante K 8 -102 ou KW 8-102 e 01 tweeter kt 305 ou kt 16



KEYBASS	DATA	-	05 - 01 - 2000
PROJETO - K 2V8		-	60 Watts rms 120 Watts p.mus.
MEDIDAS - mm	VB = 14 litros		s/ escala

