

- 01 - WOOFER K 12-134 S/T OU K 12 147 ST
- 01 - DRIVER KD 202 OU KD 110
- 01 - TWEETER KT 16 OU KT 305

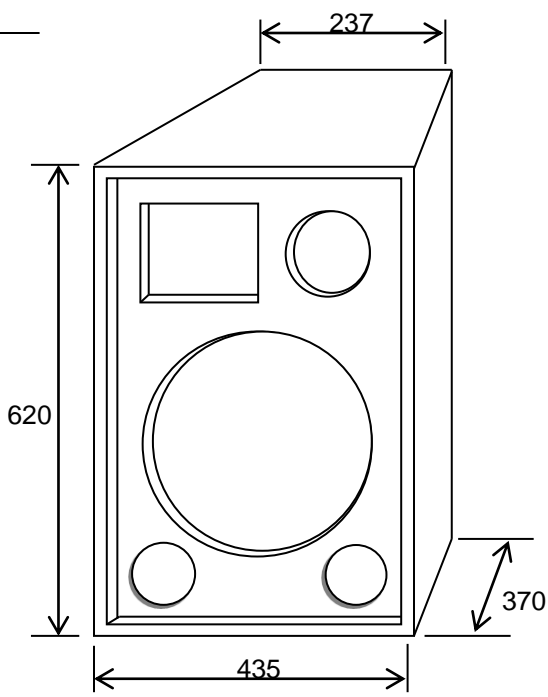

sugestão de divisor de frequências

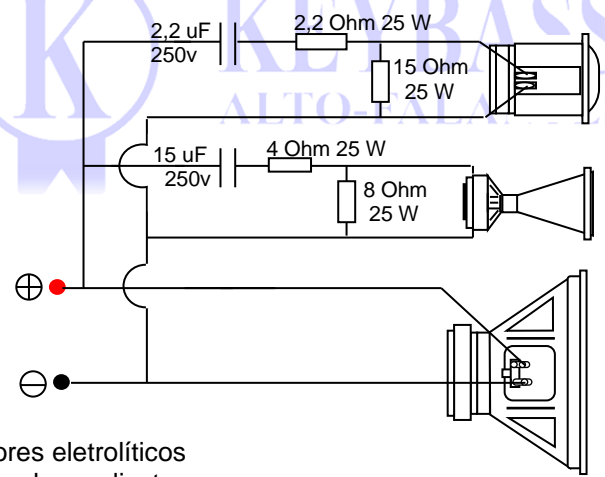

usar capacitores eletrolíticos bipolares ou de poliéster

usar compensado naval de ou MDF de 15 mm de espessura.

caixa acústica de 12" com tweeter, trapezoidal duas vias tipo bass reflex

KEYBASS	DATA	- 24 - 03 - 2003	
MODELO	-	K 3V12	
MEDIDAS	- mm	VB = 58 LITROS	s/ escala

