

- 01 - K 10-102 OU K 10-134 s/t ou K10-115 FR 2"
- 01 - KD 101
- 01 - KT 305 ou KT 16

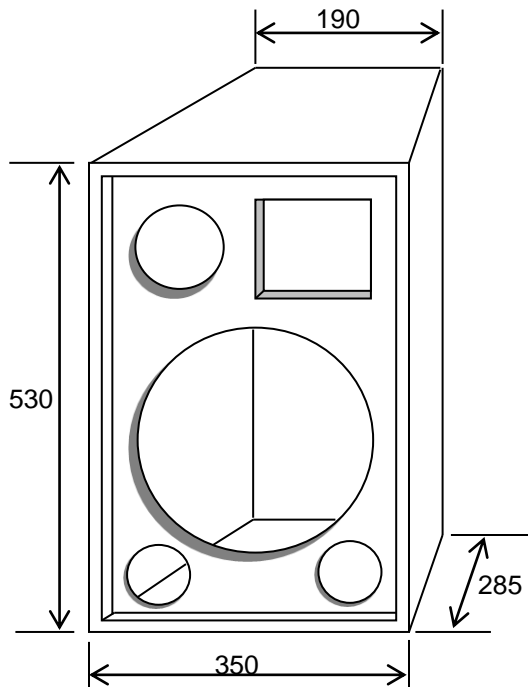

sugestão de divisor de frequências

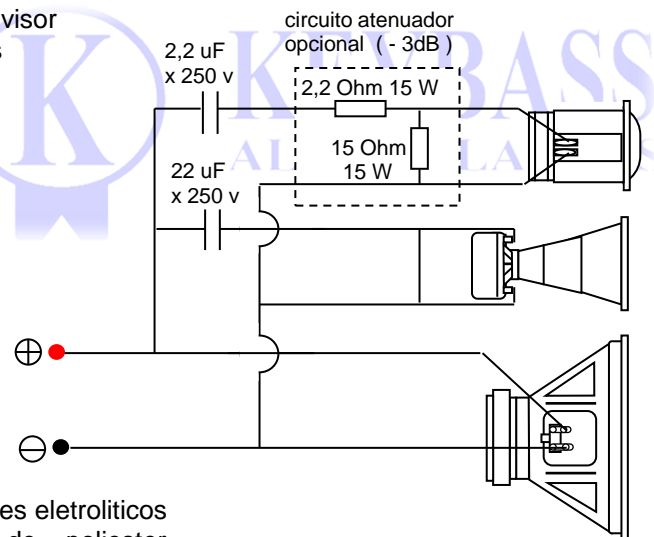

usar capacitores eletroliticos bipolares ou de poliester

usar compensado naval ou MDF de 15 mm de espessura.

Caixa acústica de 10" tres vias, trapezoidal tipo bass reflex

01 alto-falante K 10-102 ou K 10-134 s/t ou K 10-115 FR 2" , 01 driver kd 101 e 01 tweeter kt 305 ou kt 16



KEYBASS
ALTO-FALANTES

KEYBASS	DATA —	05 - 01 - 2000	
MODELO —	K 3V10		
MEDIDAS —mm	VB = 25 litros	s/ escala	

