

01 - K 10-102 OU K 10-115 fr  
01 - KT 305 ou KT 16

sugestão de divisor de frequências

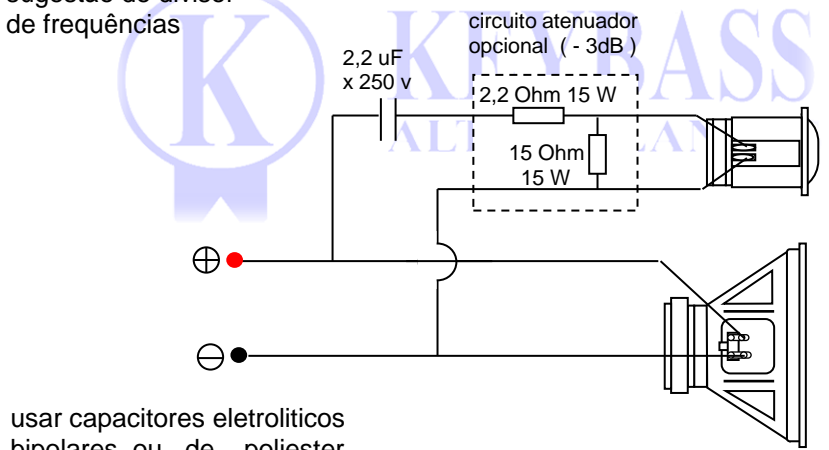

usar capacitores eletroliticos bipolares ou de poliester

usar compensado naval ou MDF de 15 mm de espessura.

Caixa acústica de 10" duas vias, trapezoidal tipo bass reflex  
01 alto-falante K 10-102 ou K 10-115 fr e 01 tweeter kt 305 ou kt 16



KEYBASS  
ALTO-FALANTES

KEYBASS	DATA -	17 - 03 - 2003	
MODELO -	K 2 V10 a		
MEDIDAS -mm	VB = 25 litros	s/ escala	



